

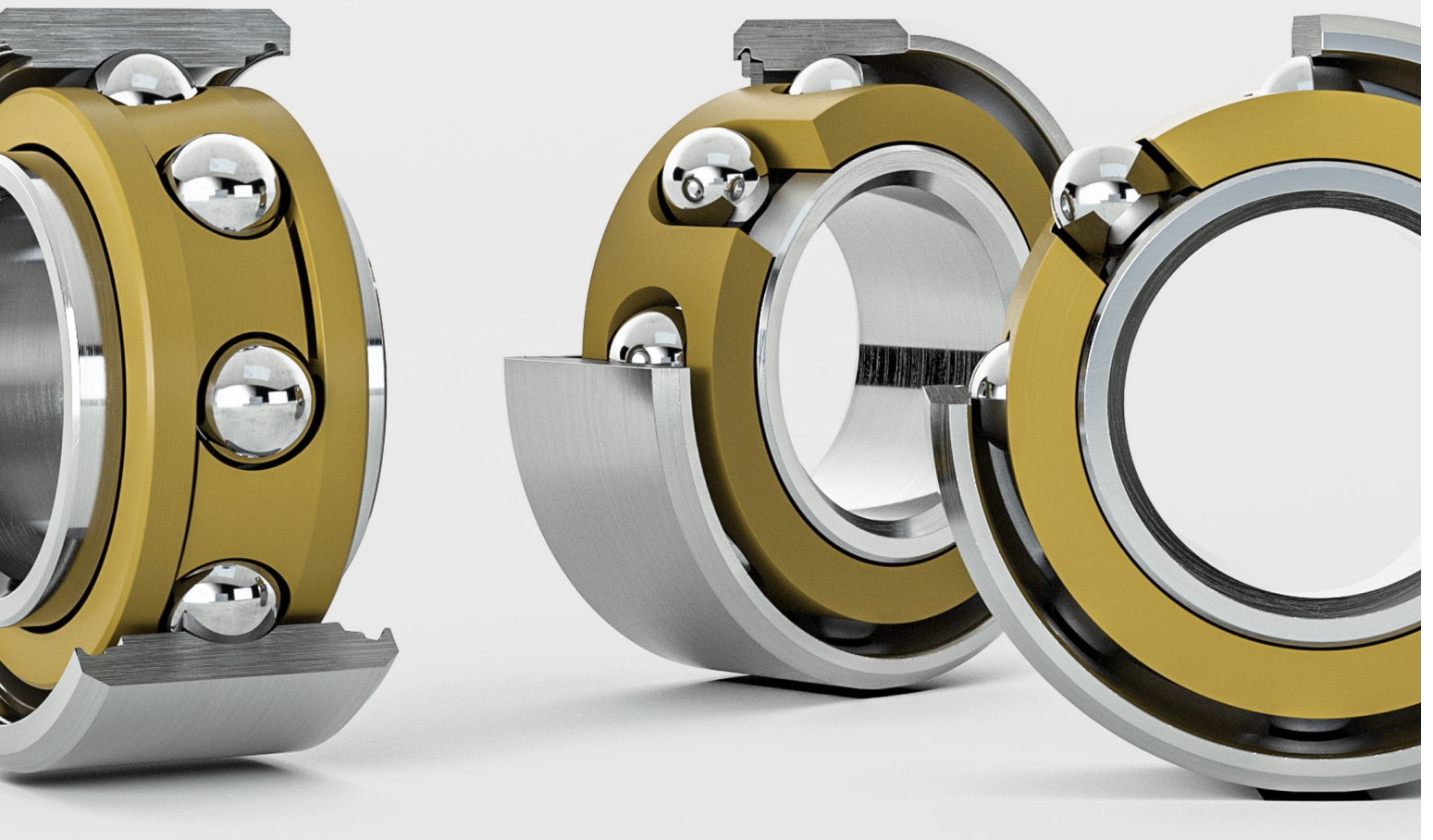

THE NEW  
PREMIUM  
Q21 BALL  
BEARINGS



# Q21-BALL BEARINGS GUARANTEE MAXIMUM PERFORMANCES THANKS TO INNOVATIVE DESIGN AND DEVELOPMENT

## Q21 IRAC®

### DENTAL BALL BEARINGS WITH THREE RADIi PROFILE

Standard ball bearings that work in tilting conditions are confronted with extreme constraining forces which lead to an early bearing failure. Not with our GRW Q21 features! In our new deep groove ball bearing Q21irac®, the angle of contact to the inner and outer ring aligns automatically and perfectly with all tilting motions during operation. The ball bearing set moves similarly to a circular orbit. Through this innovative design, noises and early bearing failures are successfully prevented. Consequently, these ball bearings are equipped with a longer service life span.

#### Maximum performances in toughest surroundings

A screeching, agonizing hum – for many people, the sound of a dentist's drill is like nails on a chalkboard. A root canal treatment, for example, is in itself an unpleasant experience. More often than not, the screeching noise of a dentist's drill only increases the discomfort of the patient. Our ball bearings - especially the three radii profile of our innovative GRW Q21 technology, are able to ease the situation. Here's how:

#### Dental hand pieces – the design of our high-tech system in focus

One important part in each dentist's toolbox is the dental hand piece. Several tools that are needed during dental examina-

tions and operations can be plugged into this main device easily.

To ensure that the tool has good access to the tooth and fits comfortably in the hand, it is equipped with an ergonomic handle design. The device allows the dentist to illuminate and clean the oral cavity and cool the drill when it comes into contact with tooth enamel. Therefore, the dental hand piece is equipped with a small light source as well as a spray nozzle. A push button at the top of the device allows the user to switch tools within seconds.



Picture 1

Inside the hand piece, a dental turbine which is accelerated pneumatically up to 500,000 rotations per minute is installed. During this process, the rotor blades are driven by the force pressurized air. There is a lever located between point of load application and the shaft nut – rotational movement of the rotor shaft results in a driving torque. With this clamping function of the shaft, the speed is transferred to the device, represented in picture 1 by a cylindrical pin. At the other end of the dental hand piece, the connection for the air supply is located. This air supply powers the motor by traveling through an internal

pipng system towards the turbine. The air is then channeled out of the handpiece via an integrated parallel aligned pipe.

### High-Precision Miniature Ball Bearings at the Dental Hand Pieces Head's Heart

In order to perform properly, a dental drill needs high-precision ball bearing solutions in miniature format. These bearings make an appearance in dental turbines. Generally, two ball bearings guarantee the necessary correct positioning and stabilization of the hollow shaft inside the housing head of the dental device and transmit the forces occurring at the drill tip via the bearings into the housing. The ball bearing consists of the following parts:

- Inner and outer rings
- Steel or ceramic balls (Ø 1 mm)
- Cages made of high-performance plastics

The ball bearings are completed with specialized seals. These seals reduce the escape of medically appropriate lubrications from the ball bearing as well as the entry of potential dirt and other unwanted particles. In picture 2, the particular model is equipped with a modified flat surface of the outer ring for this protective function. The inner rings are generally attached to the shaft with a press-fit connection. With the help of radial damper-rings and axial wave washers, the outer rings are kept in a floating position within the housing. This system allows

a vibration-reduced x-alignment to compensate axial shock loads up to a certain amount. In the application, radial deviations of the hollow shaft are mainly taken in by the front (left) ball bearing. This way, the development and manufacturing of a dental drill are a special challenge. Such a hand piece needs high durability of all high-speed ball bearings while mutually changing bending moments of the hollow shaft might appear during application. We at GRW offer an optimal solution: Our new Q21 ball bearings.

### Turbine ball bearings have to face these problems:

The harsh environment of a dental turbine is challenging for each deep groove ball bearing. After each dental operation, the hand piece is cleaned, sterilized and re-lubricated in a specific treatment process. During this cleaning interval, after a while a deficiency in lubrication is standard. The expired air does not only escape through it's intended exit – some also streams out across the ball bearings. This means, that the inserted lubrication is constantly transported outside of the housing.

Another problem for the ball bearings is the asymmetrical outer loads. These are transferred during dental operations onto the cutting edge of the drilling device. In consequence, a tilting of the rotor shaft happens. This leads to misalignments of

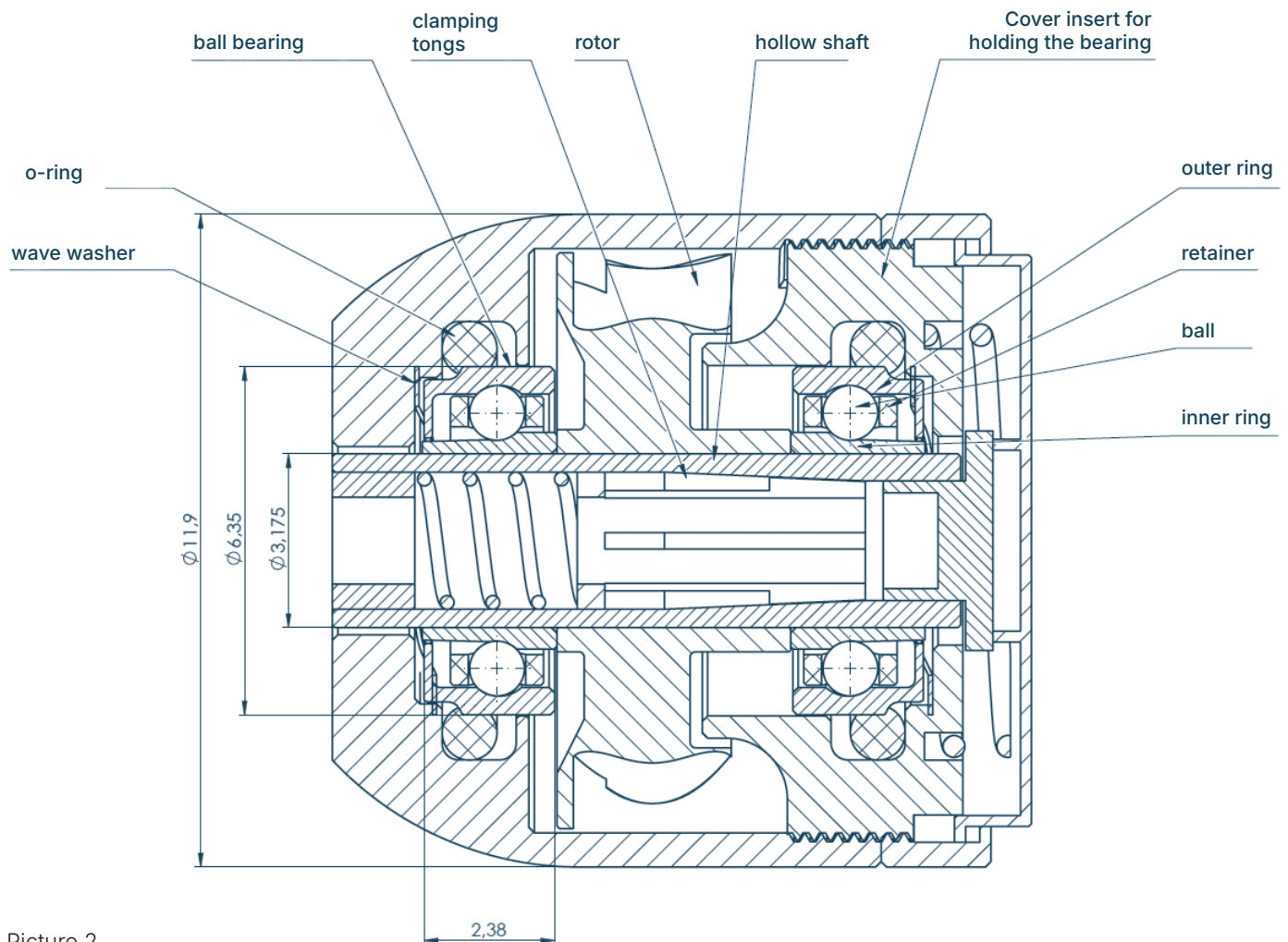

Picture 2

the ball bearings due to the diagonally positioned outer ring.

In current techniques, deep groove ball bearings that work with tilting are impinged with significant constraining forces. The balls of the bearing set are moving in elliptical lanes. This leads to slightly different circulation speeds – depending on the specific elliptical path. With fast or slow running rolling elements, the ball bearing cage experiences permanent alternating stress. Consequently, the ball bearing works under constant overload and a rapid wear of the cage appears. Early ball bearing failure is imminent. At GRW we are able to compensate for this effect with our modern XTRA high-performance plastics that contain friction reducing additives. Progressive damage leads to wear and dirt particles that are collected within the ball bearing. As a result of the increased running friction, there is a loss of speed, which in turn leads to a drop in power. Directly before the failure of the front, stressed ball bearing, the hand piece produces louder noises and seems to be grinding. These problems are directly linked to the fluctuating speeds during operation. At the same time, unpleasant vibrations are transmitted to the handle sleeve of the handpiece, which can interfere with the physician's work. Eventually, the cutting speed is no longer sufficient to process the enamel and the handpiece becomes unusable.

**Our solution: GRW Q21IRAC® –  
Specific ball bearings with particular raceway profile**

The design of a dental turbine allows no space for geometrical adjustments within the surrounding of the ball bearings. With a floating suspension of the two outer rings inside the housing, a slightly inclined position of the outer ring cannot be prevented completely. This is why the producers of dental devices cannot guarantee the given warranty. In order to solve this issue, the track design of this deep groove ball bearing needs to be adjusted in a way that all balls inside the bearing run approximately in a circular motion, even though the position might be slightly inclined. This is the only way that constraining forces on the cage, based on the various speeds inside the bearing, can be minimized or even prevented. Our GRW Q21 innovations are able to solve exactly these problems. With our patented Q21irac® special ball bearing we have found the optimal solution. This bearing has an outer ring raceway profile with three tangentially merging radii. The kinematic principle of action is described in more detail below:

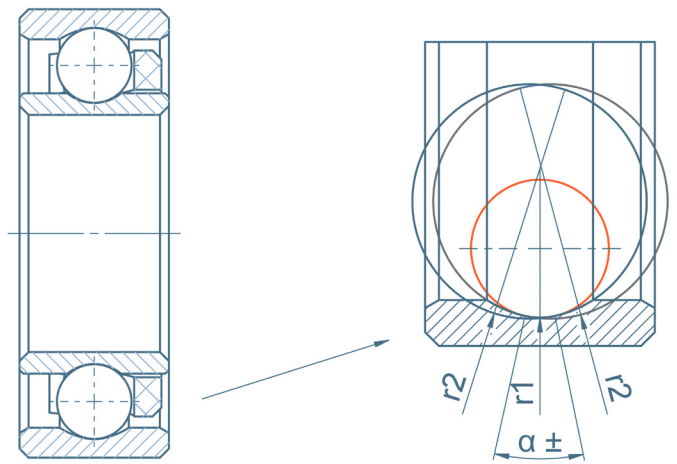

Picture 3

As can be seen in Picture 3, the outer ring raceway of the Q21irac® ball bearing is equipped with a special contour. In a regular installation position without tilting, there are basically no differences between the Q21irac® design and a standard radial deep groove ball bearing in regards to the rolling conditions of the ball bearing set. The balls move within radius  $r_1$  with the raceway angle  $\pm\alpha$ . Without considering tilt, both ball bearing variants have identical static and dynamic load ratings.

The situation is different, however, as soon as a defined tilt occurs between the inner and outer ring: Then, individual balls of the ball set move into section 2. There, the raceway radius  $r_2$  is significantly larger than  $r_1$  (approximately twice as large as  $r_1$ ). As a result, the operating contact angle shifts significantly inward towards the center of the track and the strongly elliptical shape of the track is minimized. With the innovative Q21 technology from GRW, it is possible to significantly reduce the constraining forces between balls and raceways or balls and cage. This also has a positive effect on the bearing noise. Despite the tilt, the innovative Q21 solutions from GRW are significantly quieter.

**An audible success:  
the noise test**

Of course, we have also subjected our innovative Q21irac® ball bearings to noise measurements: We perform these on our GRW noise test bench. Here, an accelerometer absorbs the vibrations on the outer ring of the deep groove ball bearing. A hydrodynamically mounted shaft drives the inner ring at 3,000 revolutions per minute.

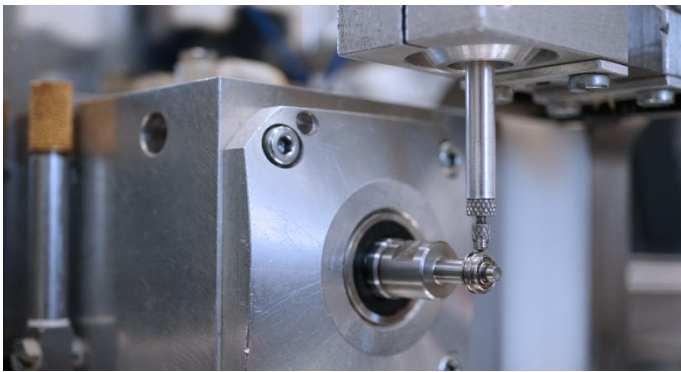

Picture 4

A piezo crystal converts the detected acceleration values into an electrical voltage. Corresponding band filters divide the frequencies into the ranges 500 to 1,600 Hz (low-band) or 1,600 to 5,000 Hz (HIGH-BAND). Occurring signal peaks are integrated over time and displayed as a „PEAK area“ (Picture 5).

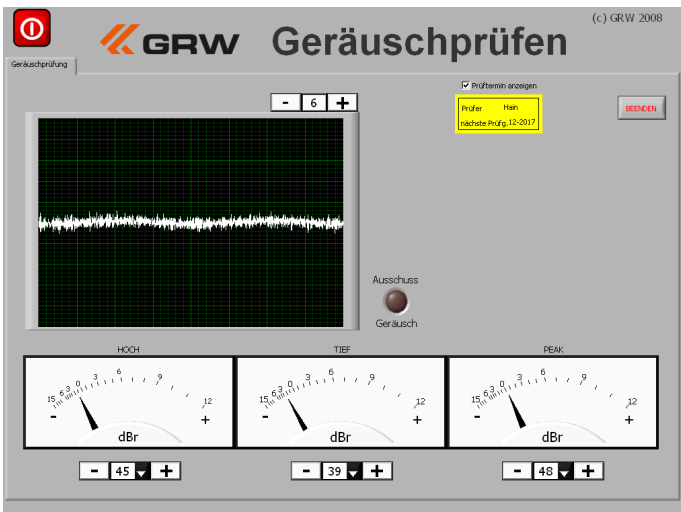

Picture 5

The noise test confirms the almost identical behavior of the two comparison bearings in a non-tilted state. As soon as the outer rings of the two bearing versions are tilted, the running noise in the standard bearing increases significantly. However, the GRW Q21irac® bearing variant with a three-radii profile shows an unobtrusive, quiet behavior in every tilt position of the outer ring.

### Results of the multibody simulation

For the multibody simulation, a dynamic model of a turbine bearing is simulated, based on the explicit dynamic method in LS-DYNA. The dynamic vibrations of the rotor bearings are simulated for the standard radial deep groove ball bearing and the Q21irac® ball bearing design with three-radius profile with combined load and inclination of the outer ring. In addition, the effects on the behavior of the cage and the ball/raceway contact are analyzed. In ball bearings of the dental turbine, the cage is considered the weakest component. Therefore,

there is a direct relationship between the dynamic vibrations and the life of the cage.

### Model description:

The following materials are used in the AC bearings (angular contact ball bearings) of the rotor bearing:

- Inner/outer rings: Martensitic stainless steel X65Cr13
- balls: Silicon nitride (Si3N4)
- Cage: Polyamideimide (PAI)

In the simulation, the housing and the balls are designed as rigid bodies. A linear elastic material model is selected for the entire rotor shaft, the inner and outer ring as well as the cage. The outer rings are connected to the housing via damper O-rings. A hyper-elastic material is used. To determine the Mooney-Rivlin material parameters, a comparison between simulation and real properties was carried out in preliminary tests. The entire model of the rotor bearing is shown in Picture 6. It consists of 545,477 nodes, 571,042 elements and 37 components.

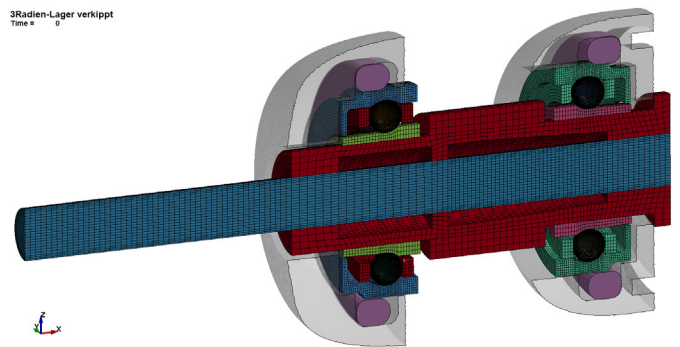

Picture 6

### Boundary conditions

In total, there are 54 main contact pairs for the model. Defined friction coefficients were selected for the following friction partners for the multibody calculation:

- Friction between balls and IR / AR track
- Friction between balls and cage
- dynamic friction for the above contacts
- Friction between housing, O-ring and outer ring

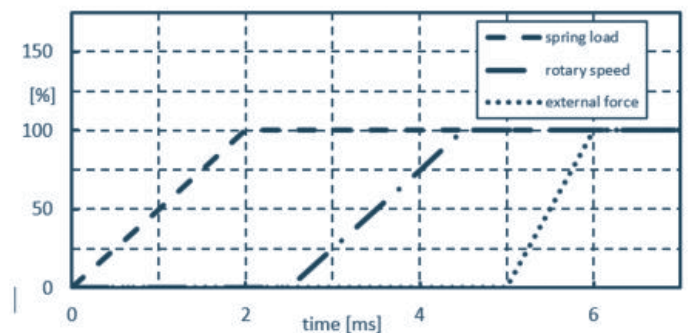

Diagram 1

The bearings are axially aligned at the end face of the outer rings with one-dimensional springs and a spring rate of 10 N/mm. The speed of rotation is transferred to the rotor shaft between the two bearings. Diagram 1 shows the time course for the activation of preload (spring force), rotation (rotational speed) and loading (force application). This takes place one after the other, taking into account a corresponding settling time.

### Results and discussion

The energy density added to the surface of the spheres over time can be read in diagram 2: Looking at the non-tilted state, both the standard bearing and the Q21irac® ball bearing from GRW with a three-radii profile show a low-energy state (3% of the maximum value). If, on the other hand, a tilt is set, this leads to a significant increase in the energy density. However, our special ball bearing with 78% energy density performs significantly better than the standard ball bearing with 100% energy density. From this energy balance, we can conclude that the vibrations transmitted to the cage are significantly lower.

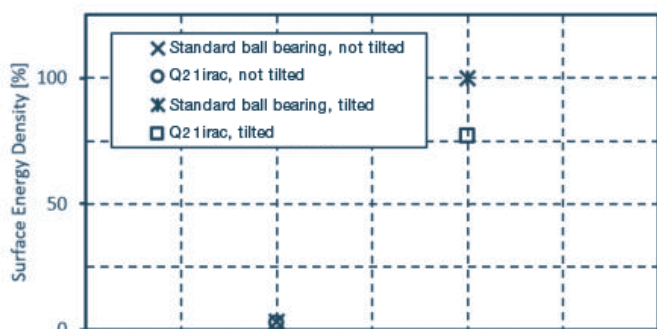

Diagram 2

To verify these results, we simulated the radial cage movements for both bearing designs in the tilted state: The diagram of the radial cage movements in the standard bearing shows that the cage is excited indefinitely by the ball set, and that its movements do not follow a specific pattern. The cage runs „restlessly“. The consequence of this is that the cage wear settles at a high level and the ball bearing is perceived as noise-intensive.

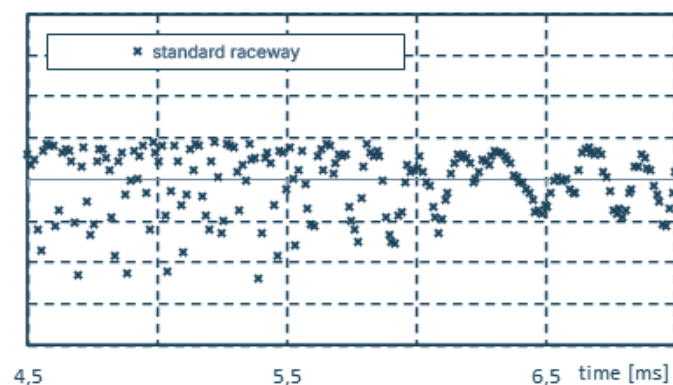

Diagram 3

The diagram for the Q21irac® ball bearing shows that its radial movement profile follows a stable sinusoidal course. This minimizes cage wear, which in turn has a positive impact on the service life and running noise of GRW's innovative Q21 bearings.

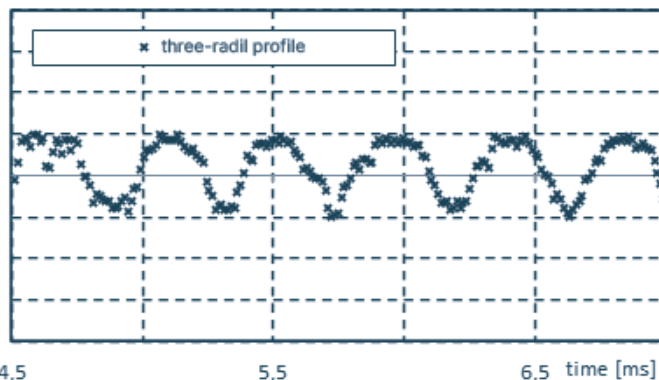

Diagram 4

### Ideal for tilted installation: Q21IRAC® ball bearings

Our new Q21irac® ball bearing design can be used successfully in applications in which the installation situation offers scope for misalignment or tilting of the bearing points. Standard deep groove ball bearings, however, are very sensitive to the influences described. Strongly scattering contact forces, that are transferred from the ball set to the cage lead to undefined radial cage movements. Consequently, the cage will be stimulated to vibrate and a high level of wear occurs. Standard bearings that are tilted are perceived as „susceptible to noise“ and fail significantly earlier than bearings that do not tilt. At GRW we can help with our Q21irac® ball bearings! The patented three-radii profile in the outer ring raceway provides the optimal solution. With the help of the GRW noise test and the FE simulation, we were able to demonstrate that our innovative solution can compensate for a tilted installation position much better than current standard products.

When our special ball bearings are used in dental turbines, they enable patients to have a significantly quieter, more pleasant experience. Also for the dentist, dental handpieces with the innovative Q21irac® ball bearings are a real asset. The longer service life span of the turbine reduces replacement costs.

## NEW CAGE DESIGN FOR DEEP GROOVE BALL BEARINGS IN HIGH-SPEED APPLICATIONS

Using GRW Q21speed®, a new cage design for high-speed deep groove ball bearings, we achieve a significant increase in performance in terms of dynamic behavior and running friction. The ball pocket design patented by GRW also guarantees a significant increase in service life spans with extremely quiet running. Both snap cages in radial deep groove ball bearings and window cages in angular contact ball bearings can be equipped with this special GRW Q21 feature.

### Design and material of the cages depend on the use of the ball bearings

Ball bearing cages face different tasks in the operation of a ball bearing: Among other things, they keep the balls separated from each other at an even distance. This reduces friction and heat generation. It also enables an even load distribution, which has a positive impact on the service life of the bearings. The cages are available in different materials and designs - depending on the task of the ball bearing. At particularly high speed, for example, plastic cages are used - either as a snap cage variant in the radial deep groove ball bearing or as a window cage in the angular contact ball bearing.



Deep groove ball bearing with inner ring, outer ring, window-type cage and ball set



Angular contact ball bearing with inner ring, outer ring, snap-type cage and ball set

Whether speed behavior, vacuum suitability, heat resistance, wear or running friction - no matter what the customer requirements are:

GRW offers a suitable solution for every application, such as:

- PAI (XTRAlon®, Torlon®)
- PI (VespeI®, Meldin®)
- PPS
- PEEK
- Reinforced phenolic resin

Sliding optimization of the polymers using solid additives (e.g. PTFE, graphite, MoS<sub>2</sub>) can largely reduce the friction behavior of the cage or the ball bearing in the non-measurable range.

### Our new cage design – GRW Q21SPEED®

We at GRW have taken the design of our ball bearing cages to the new level with our innovative Q21 features. This innovative solution is characterized by improved dynamic behavior and minimal running friction. Therefore, it is ideally suited for applications with particularly high bearing speeds. Our innovative GRW Q21speed® cage unfolds its full strength there. This is available for our complete product portfolio in the area of radial deep groove ball bearings and angular contact ball bearings.

Using the example of the window cage, we present the new design of the ball pocket. The pocket design is not a cylindrical bore as in conventional designs, but rather a funnel or cone shape in the circumferential direction. The radial pocket delimitation is oriented precisely to the center of the cage. The axial expansion of the ball pocket does not change compared to the standard.

Thanks to this special design, GRW can use this Q21 technology to achieve optimal running properties of the cage within the ball bearing. On the one hand, the driving force of the ball acts vertically against the wall of the ball pocket, so that the cage receives stable guidance and overall improved centering behavior. On the other hand, the cage is effected less by vibrations. As a result, the noise behavior and the service life of the bearing improve significantly.

We recommend plastic cages with the patented GRW Q21 design especially for high-speed applications when the speed characteristic is bigger than 400,000 mm/min. Typical fields of application are:

- High speed dental instruments
- High frequency spindles

**Test results with our new cage design compared to the standard model**

Our newly designed cage design is superior to the standard. This is demonstrated by our application example, which relates to the use of our innovative solution in a dental handpiece: With the help of our GRW reference turbine, which is operated at approx. 350,000 min<sup>-1</sup>, we were able to compare ball bearings with GRW Q21speed<sup>®</sup> cages and standard ball bearings directly. In the application example, the speed parameter is around 1,670,000 mm/min. With ten comparison turbines each, we objectively determined the service life values with the different ball bearing designs on the fully automatic GRW dental test bench.

We proceeded as follows:

- In the test mode, the drilling tool clamped in the respective handpiece rotates at the idling speed mentioned at a supply air pressure of 3.0 bar.
- A load cylinder simulates the forces exerted by the dentist, so that a certain amount of cage wear occurs as a result of the accelerations and decelerations in the ball bearing. This in turn is directly proportional to the running friction.
- Increasing the friction within the ball bearing leads to a drop in the speed of the turbine after a certain time
- If the turbine falls below the speed limit of 330,000 min<sup>-1</sup>, the handpiece is considered to have failed.
- After the failure of all 10 test turbines, the tests were evaluated and compared.

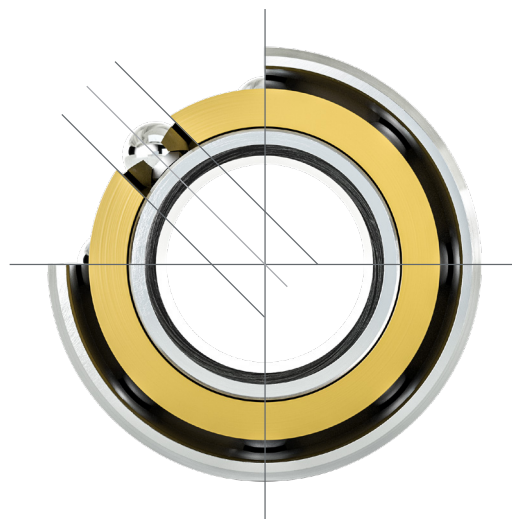

cage pocket with cylindrical bore in standard cage

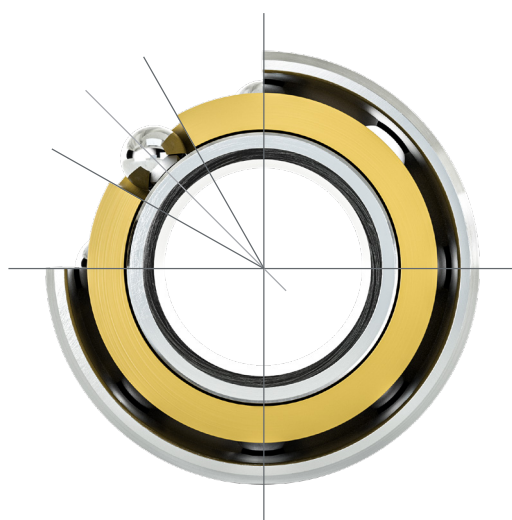

cage pocket with funnel-shaped contour in special design

In the test mode, we also recorded the speed behavior and the noise of the turbine, because dental device manufacturers attach particular importance to these parameters. The results of our measurements can be seen in diagram 1. It shows the idle speeds (turbine speed) and the service life values (turbine life span) in a direct comparison. With the GRW Q21speed<sup>®</sup> design (funnel retainer), harmful friction on the contact surface between the ball and ball pocket can be avoided completely. As a result, an average of 10,000 min<sup>-1</sup> higher idle speed can be applied in comparison to the standard bearing.

## NEW CAGE DESIGN REALIZES THE USE OF WINDOW CAGES IN RADIAL DEEP GROOVE BALL BEARINGS

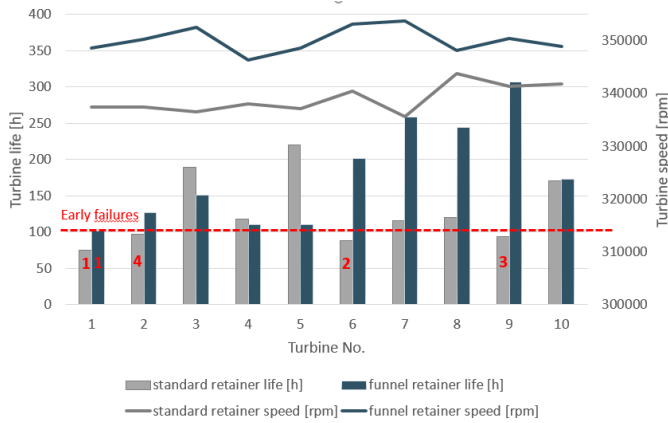

Diagram 5

With our Q21speed® technology, the average service life span is 178,3 hours. With a standard ball bearing, however, it is only 128,7 hours. Looking at early failures is much more important for the performance of the storage. With Q21speed®, the force is applied tangentially at the ball / ball pocket contact point. This means that when the cage begins to wear, it doesn't move out of the center position. This can prevent premature bearing failures. Diagram 1 shows the early failures for both bearing variants with a lifespan of up to 100 hours in red letters. While four early failures are registered in the standard bearing, the GRW Q21speed® ball bearing resulted in only one - just below 100 hours.

Another important criterion regarding quality is the noise behavior of the ball bearings in the dental turbine. Here too, our innovative Q21speed® design out-performs other solutions with a running noise of approx. 60 dB. The standard ball bearing is significantly more noticeable at around 64 dB.

### Optimal working characteristics thanks to the GRW Q21 technology

With our GRW Q21speed® cage design, we have developed an innovative solution for high-speed ball bearings. They convince with their improved, dynamic behavior and minimal running friction. The ball pockets of the cage are designed differently from conventional variants in the form of a funnel or cone. Thanks to the diagonally arranged contact lines of the funnel-shaped ball pockets, we at GRW have achieved optimal conditions with our Q21 technology. With the Q21speed® cage design, the driving force of the ball acts vertically against the wall of the ball pocket. This gives the cage more stable guidance and improved centering behavior. In addition, it is not as susceptible to vibrations – this ultimately has a positive effect on the noise behavior and the service life span of the ball bearing. Our new Q21speed® cage design can be installed in window cages for angular contact ball bearings as well as in snap cages for radial deep groove ball bearings.

Our new patented cage design Q21twin allows the use of solid cages in deep groove ball bearings where previously only snap-type cages could be used. Thanks to our innovative solution, there is a noticeable increase in performance in radial deep groove ball bearings. Contrary to the usual snap cages, the new Q21 technology by GRW combines two cage halves in a form-fitting manner to build a window cage in a radial deep groove ball bearing. This combination of two mutually flexible cage halves enables:

- Axial compensation of the cage halves to each other when the ball bearing is tilted
- Interception of external forces on the cage, which arise, for example, from the balls moving forward or backward on the cage

The GRW Q21 technology prevents constraining forces on the cage. This reduces wear in the ball bearing and ultimately has a positive impact on the availability and service life of the application.

### These restrictions previously applied to ball bearings

Regardless of the individual customer requirements and cage materials, the following restrictions apply to a ball bearing:

- Only snap cages or two elaborately riveted or reshaped cage halves can be installed in radial deep groove ball bearings.
- If massive window cages are to be used, angular contact ball bearings with a shoulder that is ground on one side need to be built-in. However, this increases the manufacturing efforts and thus also the costs. In addition, such angular contact ball bearings can only be axially loaded in one direction. This leads to increased assembly effort and problems with disassembly. Another disadvantage of shoulder ball bearings in dental handpieces is the risk of bearings disintegrating during handling due to the bearing design.

**Our technology provides an alternative**

We have developed the ideal solution for you with which these restrictions belong to the past: Our GRW Q21twin® cage design. This two-part window cage consists of two halves, which are connected to each other in a form-fitting manner using the ball set. This results in a window cage that can be installed in a radial deep groove ball bearing. Another plus is the flexibility of the two cage halves to each other: thanks to this cage geometry, axis compensation is possible when the ball bearing tilts during operation.

This minimizes the constraining forces acting on the cage. Since the cage halves can also be rotated relatively to one another in the circumferential direction within the ball pocket play, these external forces on the cage can be absorbed. Ultimately, these aspects have a positive effect on the wear and the service life span of the ball bearing cage.

For Q21twin® you can use any high-performance plastic from our range of GRW cage materials.

**Can only be realized for an even number of balls**

With our new GRW Q21twin® design, you only have to accept a limitation in the number of balls. This results from the symmetrical structure of the two halves. Q21twin® can therefore only be realized with an even number of balls.

**GRW Q21TWIN® compared to standard cages: our test results**

To illustrate the capabilities of our innovative Q21twin® solution, we compared the new cage design with the standard variants of snap cages in radial deep groove ball bearings and window cages in identical shoulder bearings:

- We carried out the tests on the GRW test bench using a reference turbine, which is operated at approx. 350,000 min<sup>-1</sup>.
- In the application example, the speed characteristic value is approx. 1,670,000 mm/min.
- The failure criterion of the application is the drop in speed due to wear in the ball bearing.

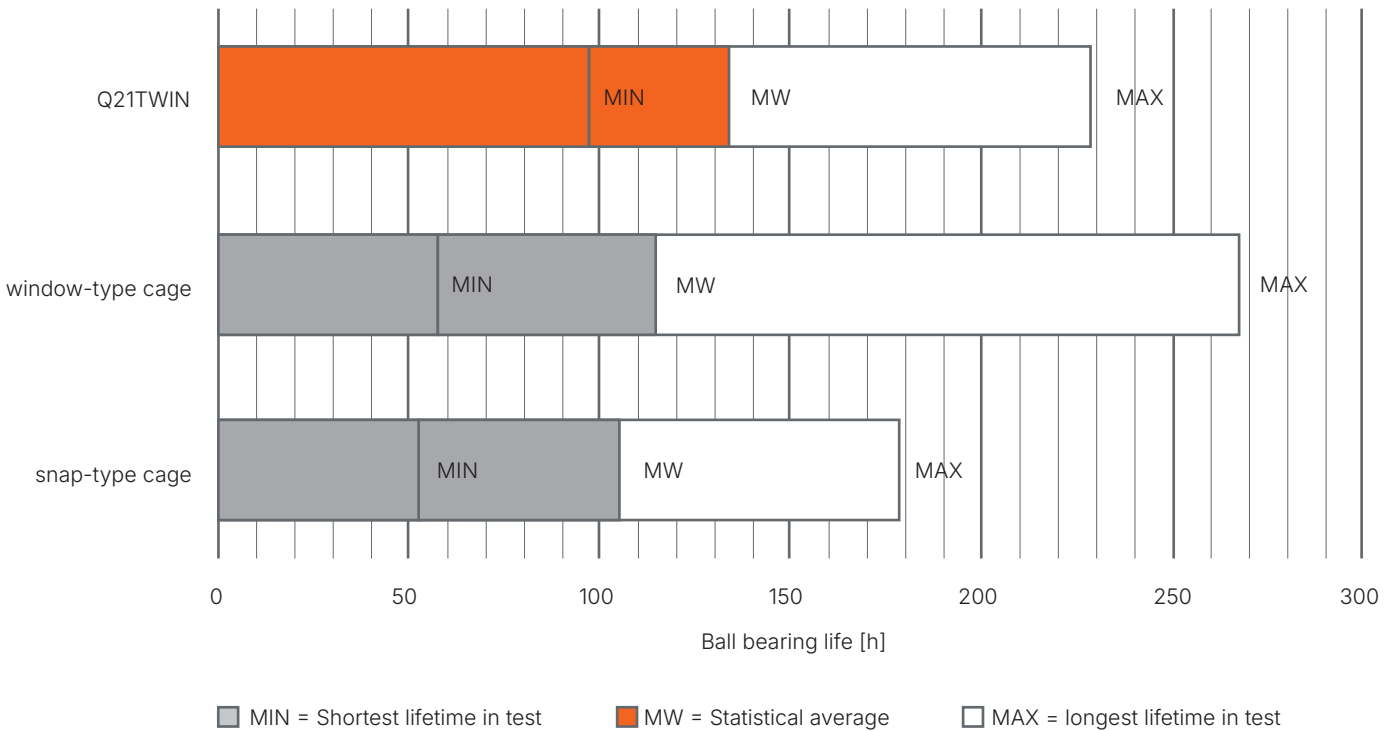

Diagram 6

Thanks to the flexibility of the cage halves and the reduced wearing process in the ball bearing, the following advantages of our GRW Q21twin® can be seen in the service life span test:

- The snap cage in a standard deep groove ball bearing shows a solid service life span with few early failures.
- The window cage in an identical shoulder bearing has a 10% longer life span compared to the snap cage. There were also few early failures and a longer lifespan of the window cage.
- GRW Q21twin® shows the best service life among the tested hand pieces. Compared to the snap cages in the radial deep groove ball bearing, the characteristic service life span is increased by 25%. There are also no early failures with the two-part window cage. With only one long-run bearing, this represents the best performance among the hand pieces.

With regards to the idle speed, the proven snap cage shows its expected friction advantages: It has a 5 to 10% higher idle speed. The Q21 technology developed by GRW and the window cage are on the same level. Q21twin® can also keep up regarding the running noise.

**Take your application to a new level with our GRW Q21TWIN®**

With Q21twin®, GRW offers our customers an ideal economic and technical solution that leaves previous restrictions behind. The combination of two mutually flexible cage halves offers several advantages.





**Gebr. Reinfurt GmbH & Co. KG**

Niederhoferstraße 105  
97222 Rimpfing  
Germany  
Phone: +49 (0) 9365 819-0

**GRW High-Precision Bearings LP**

1330 Blue Hills Avenue  
Bloomfield, Connecticut 06002  
USA  
Phone: +1 (860) 243-97 04

**Kaman Specialty Bearings Pte. Ltd.**

350 Orchard Road  
#11-08 Shaw House, Suite 16  
Singapore 238868  
Phone: +65 6725 9861

Digital version

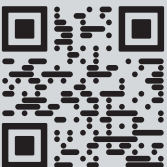

E-Mail: [info@grw.de](mailto:info@grw.de)  
[www.grw.de](http://www.grw.de)